







# ALCOR - LED-Spiegel



-  IP44
-  Niedriger Verbrauch. Led Samsung.
-  Norm CE
-  5 Jahre Garantie
-  Spiegel mit Hintergrundbeleuchtung
-  Sensor anti-beschlag

## Technische Eigenschaften

	600	700	800	900	1000	1200
Kelvin	5700 (cool light)					
Lúmenes	410	690	750	780	820	860
Wattios	6+21		10+21		12+32	
Korrosionsschutz	No					
Energieeffizienz	E		D		E	
Glasdicke	4 mm					
CRI	>90					
Lebensdauer	5000 h					

## Produktabmessungen

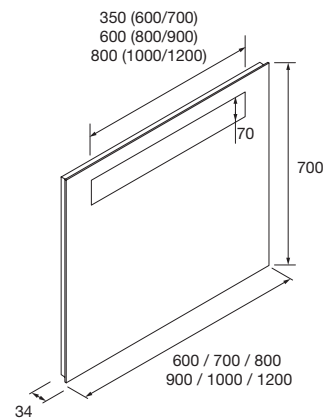

## Abmessungen und Verpackungsgewicht

	600	700	800	900	1000	1200
Länge (mm)	685	785	885	985	1085	1285
Tiefe (mm)	75					
Höhe (mm)	765					
Nettogewicht (kg)	4.05	4.9	5.35	5.9	6.9	7.7
Bruttogewicht (kg)	4.85	5.06	6.55	6.9	7.9	8.95

## Installationsmessungen

