

RENOIR - 2 drawers - 600/800/1000

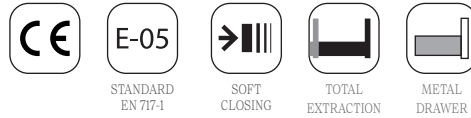

Exterior finishes

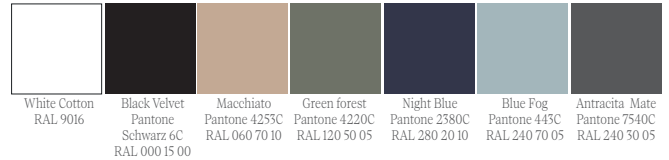

Interior finishes

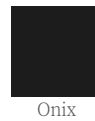

Technical information

Front panels (thickness=19mm):

- Water-repellent MDF board with moulding design and 3D lacquered with matt water-based paint.

Side panels (thickness =16mm):

- Laminated particle board 3D lacquered with matt water-based paint.

Internal Structure panels (thickness = 16mm): Laminated particle board onix.

* All boards used in the manufacture of this furniture are classified as class E05 with low formaldehyde content.

*Edges according to design: PVC, ABS. (edged with PUR glue)

Fittings

Hangers: Heavy duty hanger with three independent adjustments accessible from the front. Load capacity 70Kg.

Drawer: Grass V8 metal drawer. Hidden high-end full-extension slides with cushioned closing and lateral and height adjustment. Max. load capacity 40 Kg.

Handles Handle, knob or shell in different finishes. Not included in the unit.

Compatible Washbasins

Integrated Washbasins

- 600/800/1000: Constanza, Veneto, Vilna, Toscana.

Countertop basins

Altiro, Seduction, Kandy, Lokum, Varmega, Tenta, Verila, Nesla, Ellen, Bol, Bulkan, Bica, Talea.

Semi inset basins with counter top

Mael

Packaging dimensions and weight

	600	800	1000
Lenght (mm)	660	860	1060
Depth (mm)	510		
Height (mm)	610		
Net weight (kg)	23,5	28,1	32,8
Gross weight (kg)	25,8	30,8	35,8

Dimensions

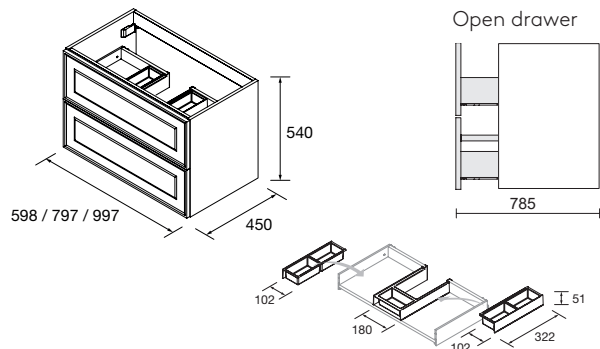

Handle models

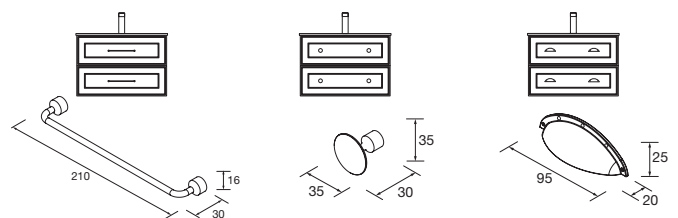

Back free space for water conections

