







## ALCOR - Espejo luz led



-  IP44
-  Iluminación de bajo consumo. Led Samsung.
-  Marcado CE
-  5 años de garantía
-  Iluminación de trabajo
-  Sensor antivaho

### Características Técnicas

	600	700	800	900	1000	1200
Kelvin	5700 (cool light)					
Lúmenes	410	690	750	780	820	860
Wattios	6+21		10+21		12+32	
Anticorrosión	No					
Eficiencia energética	E		D		E	
Espesor de la luna	4 mm					
CRI	>90					
Vida útil	5000 h					

### Dimensiones producto

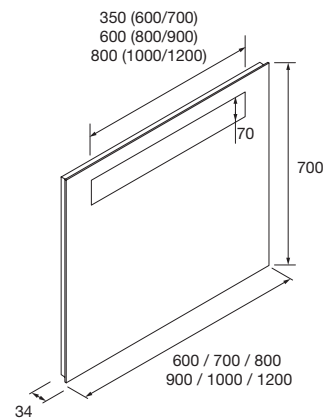

### Dimensiones y peso embalaje

	600	700	800	900	1000	1200
Longitud (mm)	685	785	885	985	1085	1285
Profundidad (mm)	75					
Altura (mm)	765					
Peso neto (kg)	4.05	4.9	5.35	5.9	6.9	7.7
Peso bruto (kg)	4.85	5.06	6.55	6.9	7.9	8.95

### Medidas de instalación

