

Accessoires OMEGA - Anneau

Information produit

- Code: 23498
- Typologie de produit: Anneau
- Catalogue: Catalogue Général
- Famille: Omega
- Dimensions: 200 x 200 x 80 mm
- Matériaux: Laiton
- Finitions:
 - Éclat de chrome



Finitions

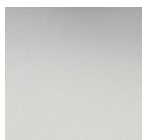

Éclat de chrome

Dimensions

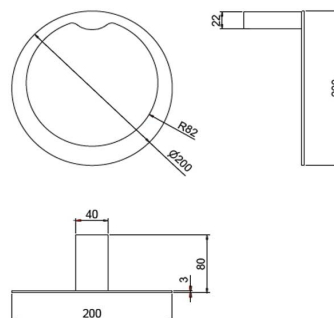

200 X 200 X 80 mm