

ALCOR - Specchio con LED



-  IP44
-  Basso consumo. Led Samsung.
-  Norma CE
-  5 anni garanzia
-  Specchio retroilluminato
-  Sensor antiappannamento

Caratteristiche tecniche

	600	700	800	900	1000	1200
Kelvin	5700 (cool light)					
Lúmenes	410	690	750	780	820	860
Wattios	6+21		10+21		12+32	
Anticorrosione	No					
Efficienza energetica	E		D		E	
Spessore del vetro	4 mm					
CRI	>90					
Vita utile	5000 h					

Dimensioni del prodotto

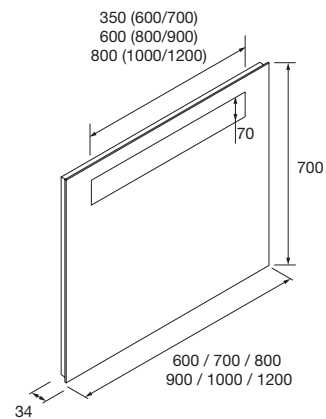

Dimensioni e peso dell'imbballaggio

	600	700	800	900	1000	1200
Lunghezza (mm)	685	785	885	985	1085	1285
Profondità (mm)	75					
Altezza (mm)	765					
Peso netto (kg)	4.05	4.9	5.35	5.9	6.9	7.7
Peso lordo (kg)	4.85	5.06	6.35	6.9	7.9	8.95

Misure di installazione

