





ALCOR - Espelhos com luz led



-  IP44
-  Baixo consumo Led Samsung.
-  Norma CE
-  5 anos garantia
-  Espelho retroiluminado
-  Sensor antiembaciamento

Características técnicas

	600	700	800	900	1000	1200
Kelvin	5700 (cool light)					
Lúmenes	410	690	750	780	820	860
Wattios	6+21		10+21		12+32	
Anti-corrosão	No					
Eficiência energética	E		D		E	
Espessura da luna	4 mm					
CRI	>90					
Vida útil	5000 h					

Dimensões do produto

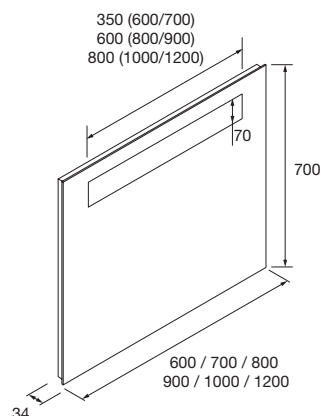

Dimensões e peso embalagem

	600	700	800	900	1000	1200
Comprimento (mm)	685	785	885	985	1085	1285
Profundidade (mm)	75					
Altura (mm)	765					
Peso líquido (kg)	4.05	4.9	5.35	5.9	6.9	7.7
Peso bruto (kg)	4.85	5.06	6.55	6.9	7.9	8.95

Medidas de instalação

