

NOJA- Vanity 2 drawers - 600/700/800/900/1000/1200 (2x600) /1400 (2x700)



Exterior finishes



Interior



Technical characteristics

Front & side panels (Thickness=16mm):

- Gloss White: Laminated particle board lacquered with UV high gloss polyester paint.
- Matte grey, Eternity oak, Caledonia oak: Laminated particle board.

Internal structure panels (Thickness=16mm): Laminated particle board.

- * All the panels used in the manufacture of this unit are classed as E-05 grade with low level of formaldehyde content.
- * Trim varies according to design: PVC, ABS (edged with PUR glue)

Drawers: Wooden drawer with concealed partial extraction runner with soft closing and height adjustment. Maximum load capacity 25 Kg.

Metal fitting

Cabinet hangers: Heavy duty hanger with three independent adjustments accessible from the front. Load capacity 70Kg.

Wash basins available

- 600/700/800/900/1000: Iberia
- 1200: Iberia double
- 1400: Toscana double sink.

Vanity dimensions and package weight

	600	700	800	900	1000
Length mm.	645	745	845	945	1045
Depth mm.	500				
Height mm.	620				
Net weight Kg.	23,2	25,5	27,1	29,5	31,6
Gross weight Kg.	25,3	27,7	30,2	32,5	34,7

Vanity dimensions

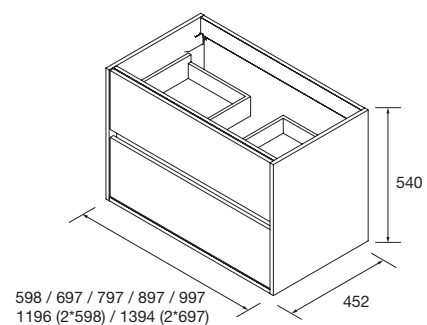

Free space for water pipe

